



**VISION GROUP**  
Shenzhen Center Power  
Tech.Co.Ltd.,

# 6FM200-X

12V 200Ah(10hr)

## Overview

The rechargeable batteries are lead-lead dioxide systems. The dilute sulfuric acid electrolyte is absorbed by separators and plates and thus immobilized. Should the battery be accidentally overcharged producing hydrogen and oxygen, special oneway valves allow the gases to escape thus avoiding excessive pressure build-up. Otherwise, the battery is completely sealed and is, therefore, maintenance-free, leak proof and usable in any position.



## Battery Construction

Component	Positive plate	Negative plate	Container	Cover	Safety valve	Terminal	Separator	Electrolyte
Raw material	Lead dioxide	Lead	ABS	ABS	Rubber	Copper	Fiberglass	Sulfuric acid

## General Features

- Positive and negative plates in lead-calcium-tin alloy;
- Stable Quality&High Reliability;
- Sealed Construction;
- Long Service Life;
- Maintenance-Free Operation;
- Low Pressure Venting System;
- Low Self Discharge;
- U.L.Component Recognition;
- Six months shelf life at 20°C;
- Design life 10 years

## Battery Specification

Performance Characteristics	
Nominal Voltage	12V
Number of cell	6
Design Life	10 years
Nominal Capacity 77°F(25°C)	
10 hour rate (20.0A, 10.8V)	200Ah
5 hour rate (36.0A, 10.5V)	180Ah
1 hour rate (128A, 9.6V)	128Ah
Internal Resistance	
Fully Charged battery 77°F(25°C)	≤4.0 mOhms
Self-Discharge	
3% of capacity declined per month at 20°C(average)	
Operating Temperature Range	
Discharge	-20~60°C
Charge	-10~60°C
Storage	-20~60°C
Max. Discharge Current 77°F(25°C)	1000A(5s)
Short Circuit Current	3300A
Charge Methods: Constant Voltage Charge 77°F(25°C)	
Cycle use	2.40-2.45VPC
Maximum charging current	60.0A
Temperature compensation	-30mV/°C
Standby use	2.20-2.30VPC
Temperature compensation	-20mV/°C

## Dimensions and Weight

Length(mm / inch)	522 / 20.6
Width(mm / inch)	238 / 9.37
Height(mm / inch)	218 / 8.58
Total Height(mm / inch)	223 / 8.78
Approx. Weight(Kg / lbs)	65.0 / 143

\* Weight deviation: ± 5%

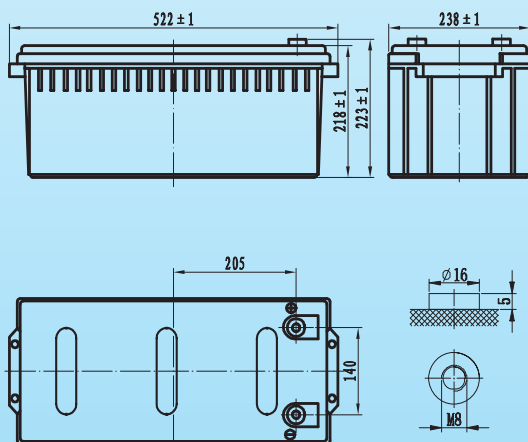

## Discharge Constant Current (Amperes at 77°F25°C)

End Point								
Volts/Cell	10min	15min	30min	45min	1h	3h	5h	10h
1.60V	--	360	220	159	128	57.6	38.2	20.4
1.65V	--	350	212	153	124	55.6	37.2	20.3
1.70V	--	337	206	149	120	55.0	36.6	20.2
1.75V	--	319	200	145	117	53.4	36.0	20.1
1.80V	--	269	187	140	114	51.0	35.4	20.0

## Discharge Constant Power (Watts at 77°F25°C)

End Point								
Volts/Cell	10min	15min	30min	45min	1h	3h	5h	10h
1.60V	--	625	402	294	230	109	73.0	40.2
1.65V	--	604	390	286	225	107	72.0	39.2
1.70V	--	586	382	279	221	105	71.2	38.4
1.75V	--	578	372	274	217	101	70.2	37.6
1.80V	--	554	364	270	215	98.0	69.3	36.7

(Note)The above characteristics data are average values obtained within three charge/discharge cycles not the minimum values.All data shall be changed without notice,Vision reserves the right to explain and update the information contained hereinto.



**VISION GROUP**  
Shenzhen Center Power  
Tech.Co.Ltd.,

# 6FM200-X

12V 200Ah(10hr)

